

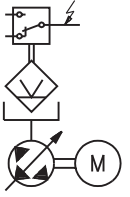

**Pump unit
GMA**



Application:

Pump unit in centralized lubrication systems

- adjustable delivery volumes
- with monitoring device
- with up to 3 pump elements
- usable for delivery of oil, semi-fluid grease or grease

- Subject to modifications -

Reservoir size Reservoir type	2 or 4l transparent	4 or 7l Galvanized sheet steel	5 or 10l Polyester
Pump unit GMA-B Drive by means of 24V direct current motor			
Pump unit GMA-C Drive by means of three-phase current motor			
electrical level control (alternativ)	for grease NLGI-class 1 and 2 (intermittently signal) for oil (float switch)	for grease NLGI-class 1 and 2 (intermittently signal) for oil (float switch)	for grease up to NLGI-class 2 (static signal) for oil (float switch)

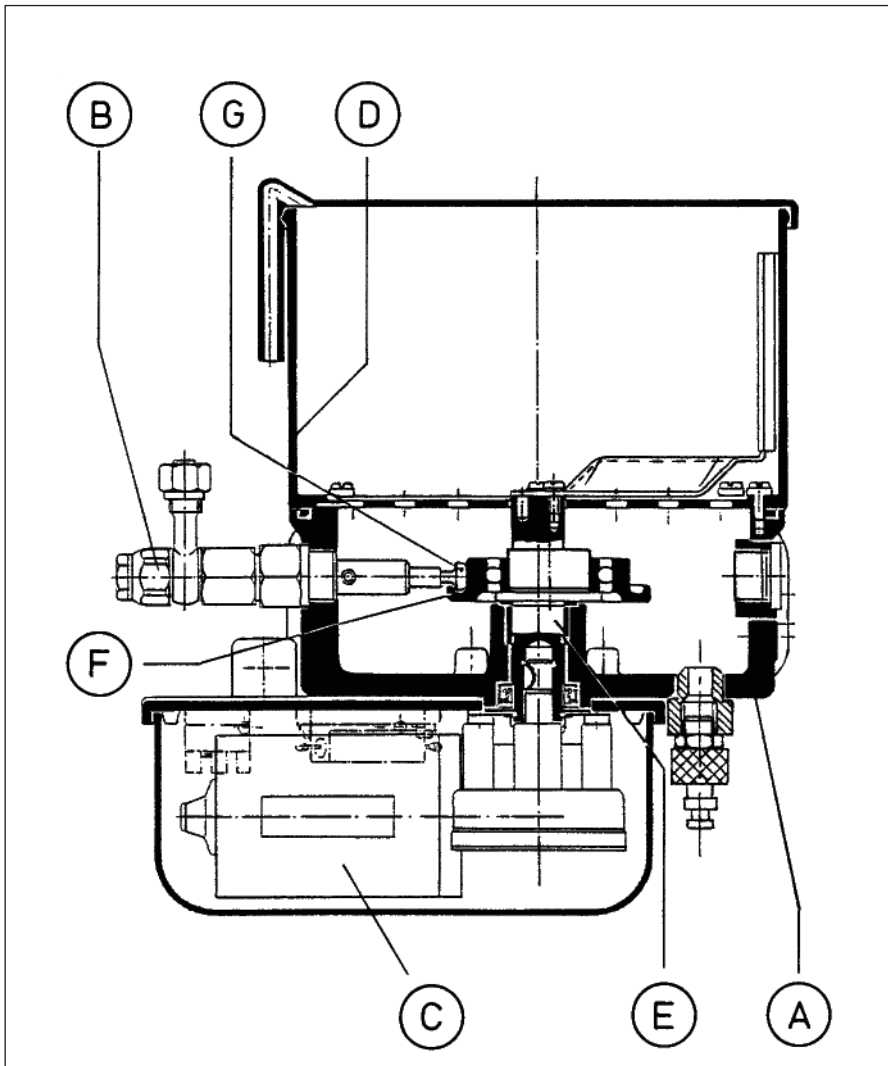

Description:

Actuation:

The pump unit GMA is actuated by a three-phase A.C. motor or a D.C. motor (C), which is flanged to the pump casing (A) from the bottom.

Pump:

At the radial piston pump there are up to three pump elements (B) arranged radially around an eccentric (F), which is surrounded by a rolling bearing. On rotation of the actuator or the eccentric shaft (E) respectively the pump piston (G) of each pump element designs a suction or a delivery stroke per revolution and thus delivers the lubricant out of the reservoir (D) to the lubricating points. The delivery volume can be adjusted at each pump element individually. Depending on the operation (lubricant, lubricant supply etc.) the pump unit can be equipped with different pump elements, reservoir and monitoring units.

Operating instructions:

For the lubrication pumps only clean oil or grease from original containers may be used. If, before putting into operation, the lubricant is not filled through the filling nipple, the pump must be filled up to the vane with gear oil during initial filling to ensure good venting. The lubricant lines must be clean and free from obstructions. Do not connect them to the lubrication points before the lubricant emerging from the lines is free from air bubbles. Check all connections of the pressure lines for leakages.

Lubricant: The intended lubricant must be suitable for use with centralized lubrication equipment.

- Subject to modifications -

Technical data:

General:

Admissible delivery pressure: approx. 250 bar
 Number of pump elements : 1 ... 3
 Delivery capacity per stroke and element:
 in case of pump element $\varnothing 6$: 0,08 cm³
 in case of pump element $\varnothing 8$: 0,15 cm³
 Temperature range:
 GMA-B: -30 ... +60 °C
 GMA-C: -20 ... +40 °C
 In case of low temperatures the grease penetration shall be regarded.
 Inserting position: vertically
 Material:
 Housing: Al
 Surface treatment: technical eloxal, black
 Pump element: Steel, galvanized
 Gaskets: NBR (Perbunane)
 Medium: Oil and grease up to NLGI-class 2
 (Mind the using conditions applicable to the reservoir and level monitoring utility!)

GMA-B:

Electrical data (motor):

Connecting voltage: 24 VDC
 Max. current: 2,5 A
 Number of rotations (depending on load)
 Connecting voltage 24 V:
 when connected
 to 1 and 3: approx. 27 min⁻¹
 Connecting voltage 12 V:
 when connected
 to 1 and 2: approx. 18 min⁻¹

Connection scheme:

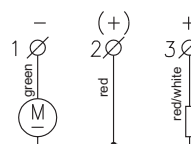

GMA-C:

Electrical data (motor):

Connecting voltage: 230/400 V (Δ/λ)
 Mains frequency: 50 Hz
 System of protection: IP55
 Insulating category: F
 Special voltage upon request

Rotations at the pump shaft	Rated power	Rated current 230/400V
① n= 1min ⁻¹	45W	0.38/0.22A
④.5 n=4.5min ⁻¹	45W	0.38/0.22A
②5 n=25min ⁻¹	90W	0.74/0.43A

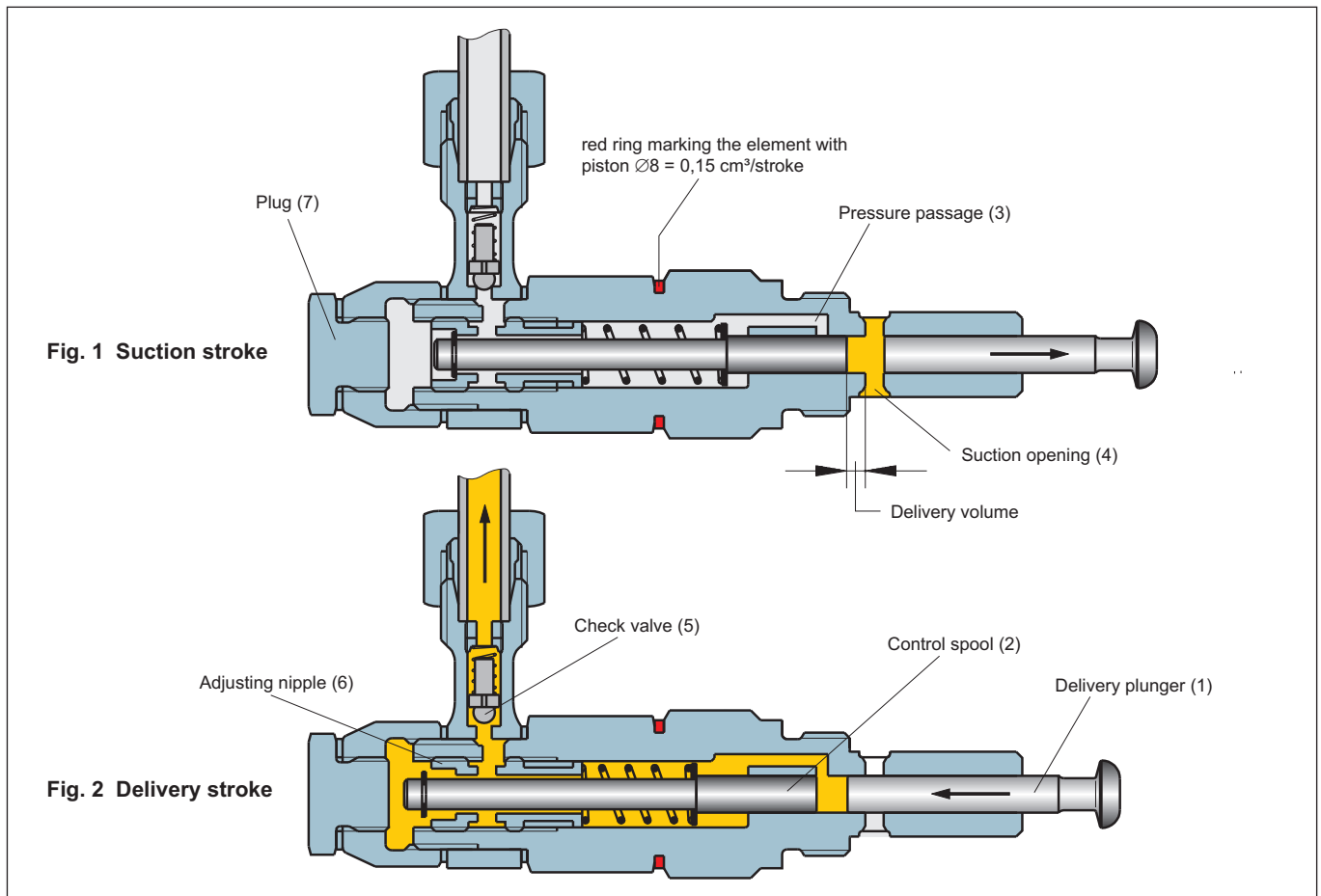

- Subject to modifications -

Operation of pump elements:

The suction stroke (fig. 1) is accomplished by the delivery piston (1) and the control piston (2). During that operation the delivery piston (1) is actuated by the eccentric shaft, and the control piston (2) by the spring. The control piston closes the pressure hole (3) and, depending on the set delivery capacity, remains at a certain position. With the delivery piston moving on, a vacuum will build up within the dosage area. After opening the suction hole (4) by the delivery piston, the lubricant starts to be sucked off the reservoir.

In case of pressure stroke (fig. 2) the delivery piston (1) moves to the left. As a result, the suction hole (4) will be closed with the lubricant available between the delivery and control pistons (2) being shifted until it clears the pressure hole (3) and the lubricant is delivered through the delivery piston up to the outlet. The pumps are supplied with their delivery capacities being set at maximum, i.e. at full stroke setting.

Delivery volume adjustment:

The **delivery volume** can be adjusted continuously between 25 and 100% of the nominal delivery volume. After having removed lock screw 7, the stroke is to be changed by means of the enclosed spanner through adjustment nipple 6. When turning the nipple to the right, delivery volume will decrease. At the adjustment nipple, there is a hexagon against which a spring loaded piston is pressing radially. Thus, any independent change of the delivery volume will be prevented. At the same time, the latching serves as a measure for setting the delivery volume. Six latches equal one rotation of the adjustment nipple and a reduction of the nominal delivery volume by 33%. 14 latches (minimum) equal a delivery volume reduction down to 25% of the nominal delivery volume.

The element with a piston diameter of 8 mm = 0,15 cm³/stroke is marked with a red ring (see fig. 1).

Installation of pump elements:

If another pump element is to be installed in the lubrication pump subsequently, proceed as shown in the drawing on the right:

Insert pump element at an upwards inclination into the locating hole with the plunger pulled out about half way. To facilitate installation and putting into operation, fill the bore taking up the plunger with grease. Bring into horizontal position and screw in only after the plunger head abuts the pressure ring and engages in the groove of the pressure ring.

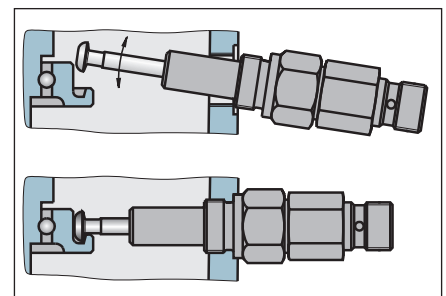



- Subject to modifications -

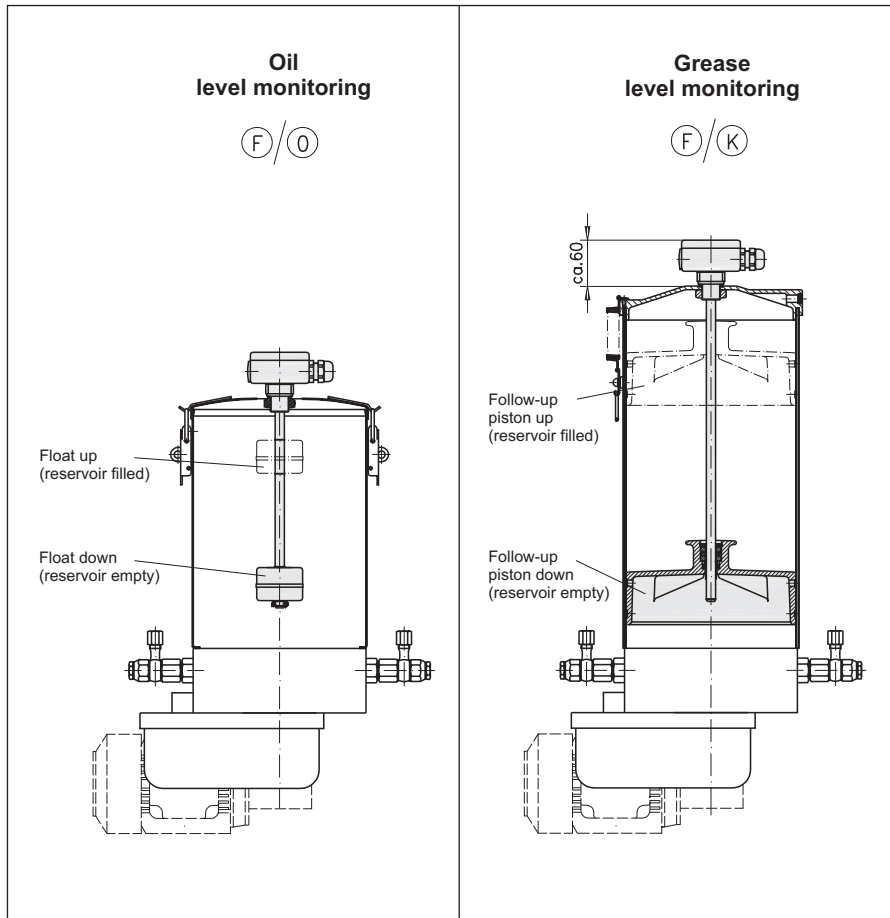

Electrical data level monitoring (F)

Switching data:
 Switching power at max.: 40 W / 60 VA
 Switching voltage at max.: 230 VUC
 Switching current at max.: 0,5 A
 * In case of d.c. with inductive load a protective circuit shall be provided for.
 System of protection: IP 65
 Type of connection: Terminal box
 Cable gland: PG 11
 Wire cross section: 0,5 ... 1,5 mm²

Connection diagram level monitoring (F)

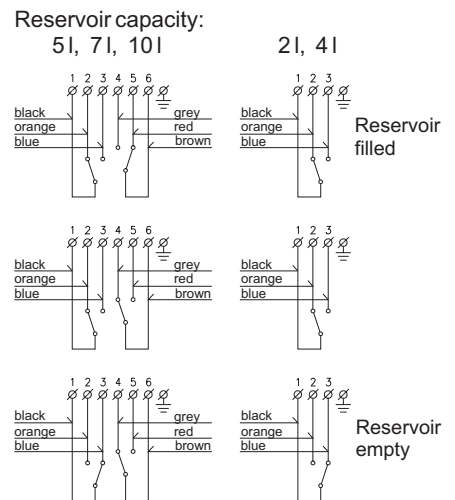

Electrical data level monitoring

by proximity switch with cable (C1)

by proximity switch with plug (C2)

Operating voltage: 10 ... 30 VDC
 Residual ripple: ≤ 10 %
 Load current at max.: 200 mA
 Inherent power consumption: approx. 7,5 mA
 Potential drop: ~0,8 V

The "empty" signal will be intermittently. The function of monitoring "C" has been tested with mineral oil-based lubricants successfully. In case of special lubricants, suitability needs to be tested.

Type of connection:
 (C1) GMA-B: Terminal strip
 GMA-C: Cable 3 m
 (C2) GMA-B: (not possible)
 GMA-C: Unit plug, 4 pins (M12) (for associated cable socket see "auxiliaries")

Connection scheme: Proximity switch with cable (C1) with plug (C2)

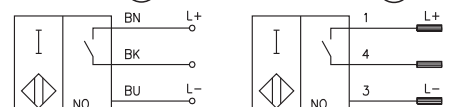

Grease level monitoring via proximity switch (C1) (C2)

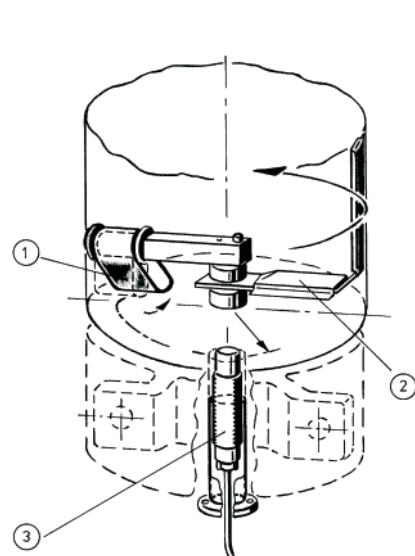

The grease inside the reservoir causes to lift up the actuating flap (1) upon rotation of the pump driving shaft. No signal will be given.

In case of an empty reservoir and a rotating pump driving shaft the actuating flap (1) will intermittently attenuate the proximity switch (3).

In case of full reservoir, the actuating flap, depending on grease penetration, may fall during standstill and attenuate the initiator (3).

Therefore, when evaluating the initiator signal, it should be ensured that the initiator signal is evaluated delayed (by approx. 10 sec).

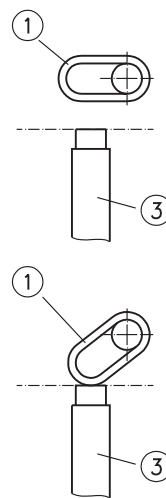

Remark on functional principle:

- 1 Actuating flap
- 2 Agitator blade
- 3 Proximity switch



Order-designation:

Pump unit



On special voltage
Voltage and frequency

Drive	Reservoir size	Level monitoring	Follow-up piston	Filling connection	Pump element						Number of revolution pump shaft ²⁾		
					left Element	left Pipe connect.	right Element	right Pipe connect.	middle Element	middle Pipe connect.			
Direct current motor 24V GMA-B	2l (Polycarbonate) 2	without monitoring 0	without 0	Flat lubrication nipple AM16x1,5 DIN 3404 C	ø6 6	ø6 6	ø6 6	ø6 6	ø6 6	ø6 6	GMA-B: no sign		
	4l (Polyamide) 4P	For oil: Min. level monitoring at reservoirs 2 4 Min. and max. level monitoring at reservoirs 5 7 10			ø8 8	ø8 8	ø8 8	ø8 8	ø8 8	ø8 8		ø8 8	
Three-phase current motor 400V/50Hz or special voltage GMA-C	4l (Steel zined) 4	without stirrer blade F with stirrer blade F1	without 0	Nipple for snap (counterpart see accessories) D	ø10 10	ø10 10	ø10 10	ø10 10	ø10 10	ø10 10	GMA-C: 1min ⁻¹ 1		
	7l (Steel zined) 7	For grease: Intermittent min. level monitoring for all reservoirs C1 C2 ¹⁾			without pump element place of installation closed							without pump element without place of installation	
	5l (Polyester) 5	For grease: Min./max. level monitoring at reservoir 5 and 10			without pump element, place of installation not closed (open treaded bore)								
	10l (Polyester) 10	with F without 0	with K with K	0	L	0	L	0	L	0	4,5min ⁻¹ 4,5 25min ⁻¹ 25		

- Subject to modifications -

¹⁾ "C2" level monitoring possible on GMA-C only

²⁾ For speed of GMA-B motor please see "technical data"

Ordering-example:

Pump unit GMA-C with three-phase motor 400V / 50Hz, motor speed 4,5, reservoir size 2l with monitoring for oil, filling connection "D", left pump element ø8 with pipe connection ø8, right pump element ø6 with pipe connection ø8

Ordering-designation:

GMA-C.B / 2 / F / 0 / D / 8 / 8 / 6 / 8 / 0 / 0 / 4,5

Accessories: (please order separately)

Counterpart to filling connection "D"

Order-no. 110.135-65

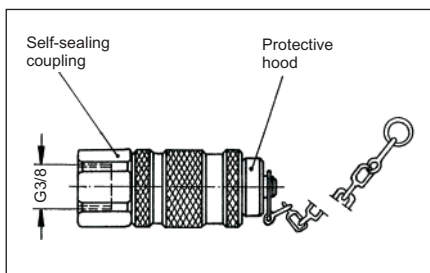

Cable socket for level monitoring "C2" with LED and 5 m cable

Order-no. 913.404-19

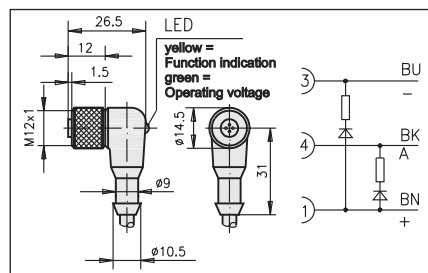

Cable cross section: 3 x 0,34 mm²
Operating voltage: 10 ... 30 VDC
System of protection: IP68
Ambient temperature: -40 ... +90 °C

Cable socket for level monitoring "C2" without LED, packageable

Order-no. 913.404-24

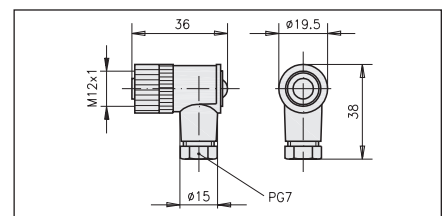

Connecting type: Screws
Connecting cross section: 0,75 mm²
Cable cross section at max.: 4 ... 6 mm
Cable gland: PG7
System of protection: IP67
Ambient temperature: -40 ... +85 °C